

ACCELEROMETER

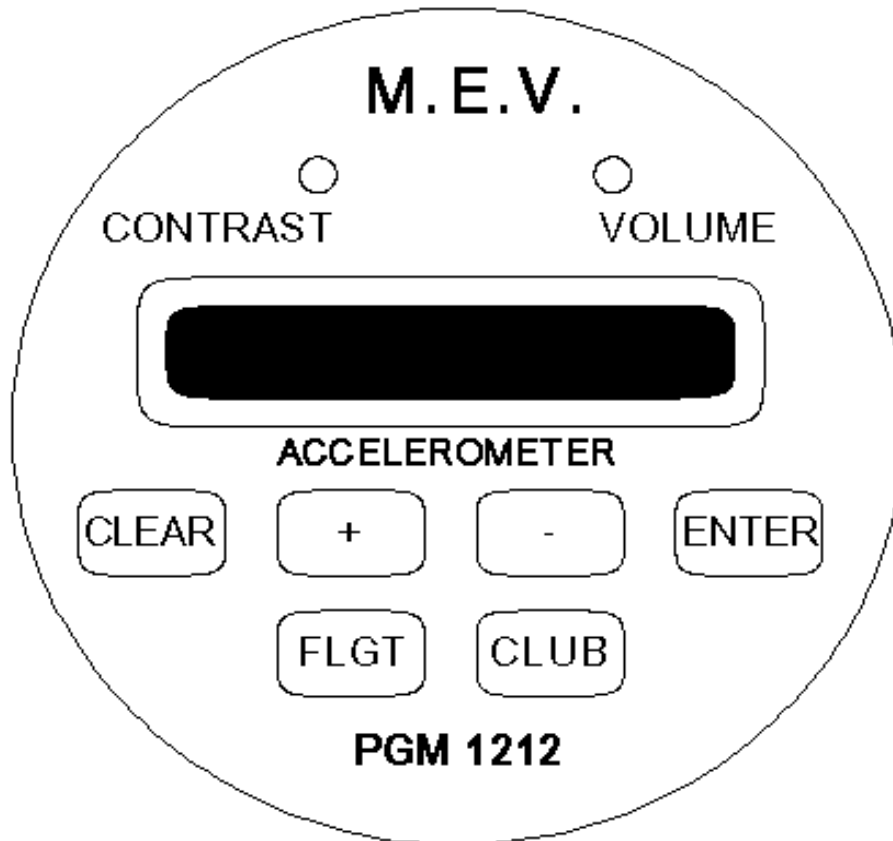

PGM 1212 V 4

V1.1 – 01/08/2006

S.A.R.L Micro Électronique VANDER ELST - M.E.V.

10 bis, route d'Ax - 31120 PORTET SUR GARONNE - Tél. : 33 5.61.72.87.00 - Fax : 33 5.61.72.87.01

S.A. au capital de 100.073 euros - Code APE 332B (2913) - SIRET 332 160 712 00037 - T.V.A. Intercommunautaire : Fr 81 332 160 712

GENERAL PRESENTATION

The PGM 1212 is a digital electronic accelerometer (i.e. it includes a microprocessor !) which has been particularly developed for aerobatics.

The whole functions of the PGM 1212 have no mechanical equivalent.

However, it is a meter and recorder G-meter which would not replace a mechanical instrument. The PGM 1212 represents its complement.

The "information" handled by the accelerometer includes figures and digital data and the aspect of the indicator display screen is as follows :

ACCEL. : +4,8 G	← Present acceleration
DUR. : 37 / 25	← Other information

In connecting a pointer indicator (much like an electronic rate-of-climb indicator) the information is displayed as usual i.e. a swinging needle going up or down (the aircraft) indicating a positive or negative figure ! Such measuring instruments exist in Φ 80 with graduating scales as following : + 6, - 4,5 G ; + 8, - 6 G ; +10, - 10 G ; + 6, -3 G.

This unit represents therefore an accelerometer which provides the exact instantaneous value of the acceleration.

The "Mini-Maxi" needles of the mechanical versions of the G-meter are being replaced by a storage facility in this equipment. The storage capacity is so high as to record many parameters and flying data.

Finally a new function is also available : the audio signal.

In connecting your headphones to the sound exit of the accelerometer, you can obtain a "bleep-bleep" in proportion to the acceleration. The more significant are the "G", the higher notes the "bleep-bleep" reaches !

It is up to you to enter the initial data of the tone (function "reading Step", see enclosed tables).

The different storage facilities are the following :

- **"Pilot" stored data** . It stores the maximums G+ and G-. Press the "+" key to obtain (on the display screen and the pointer) the maxi "+" that you memorised. Press the same way the "-" key to read the highest data reached by G-.

" + " Key →	<table border="1"><tr><td>ACCEL. : + 1,0 G</td><td>← Actual value</td></tr><tr><td>MAX PILOT : + 3,2 G</td><td>← Recorded value</td></tr></table>	ACCEL. : + 1,0 G	← Actual value	MAX PILOT : + 3,2 G	← Recorded value
ACCEL. : + 1,0 G	← Actual value				
MAX PILOT : + 3,2 G	← Recorded value				
" - " Key →	<table border="1"><tr><td>ACCEL. : + 1,0 G</td></tr><tr><td>MAX PILOT : - 1,8 G</td></tr></table>	ACCEL. : + 1,0 G	MAX PILOT : - 1,8 G		
ACCEL. : + 1,0 G					
MAX PILOT : - 1,8 G					

This storage facility can be cleared at any time by pressing the CLEAR key. You can use it to see your "G-meter" for every flying figure.

- **"Flight" stored data** . This storage facility also keeps records of the maxi G+ and G- during the whole flight ... and obviously you can consult it any time but it is impossible to clear it ! The stored data will be memorised at the end of the flight.

FLGT Key	ACCEL. : + 1,0 G MAX FLIGHT : + 3,9 G	← Actual value ← Stored value
FLGT and " - " Key	ACCEL. : + 1,0 G MAX FLIGHT : - 2,8 G	

(press both keys together)

- **"Over" stored data** . Your aircraft can be limited with "civa limits" which are lower than the manufacturer's limits.
 E.g. : + 5,0 G on a CAP 10 limited at + 6,0 G.

All data which overstress the civa data is taken into account in Step-delimited-groups. Every data overstressing the civa limit is accounted for and stored in these groups. You can read them using the function "Flight reading" pressing the ENTER key twice.

For further information, please see the enclosed tables at the end of this handbook.

All the stored flights have a number. However, on each request, you get the actual flight information (or the last flight's one if you enquire once the aircraft is on stop !).

To check on the limits of the forbidden areas, press the CIVA key.

CIVA Key	ACCEL. : + 1,0 G MAX CIVA : + 5,1 G	← Actual value ← Limit
CIVA and " - " Key	ACCEL. : + 1,0 G MAX CIVA : - 3,6 G	

(press both keys together)

This function also makes it possible for you to check the ammeter gauge. We recommend this is done before each flight.

TECHNICAL SPECIFICATIONS

- Resolution 0,1 G.
- Accuracy 3%.
- Measuring range + 12,0 G - 12,0 G.
- Pilot indicator :
 - 1) similar needle to the mechanical accelerometers.
 - 2) variable frequency audio signal.
 - 3) digital data on the display screen.
- Stored data of the last 125 flights (dates).
- Counting of the overstress s between the civa limit and the aircraft limit , in 4 positive groups and 4 negative groups.
- Power supply = 12 V aircraft 60 mA (the clock is being saved with a lithium battery) (24 on request).
- Range of temperature : 0 - 50° C.
- Weight : 650 g.
- Dimensions : Φ = 80 mm L = 140 mm (connector excluded).

Functions :

- PERMANENT measuring of the accelerations and storing of the mini/maxi (even during settings).
- Transmission of accelerations in actual time on the analogue output which can receive a central-zero ammeter.
- Storing G+/G- for the pilot. This data can be read and cleared anytime while flying just pressing 2 keys ("+" or "-" for reading and CLEAR for clearing).
- Emission of an audio signal (headphones) with a frequency varying between the starting Step (setting WITHOUT code) and the civa limit (setting of the acoustic level (volume) from the panel with a screwdriver).
 - Calculation of the total flying time in hundredths.
 - Calculation of the aerobatics time in hundredths.
- Unlocking and storing a warning signal when overstressing the aircraft limit (the warning alarm being removed with a PIN code).
 - Automatic detection of the starting of the flight.
 - Automatic switching off at the end of the flight.
- The pilot can check while flying :
 - * The maxi G+/G- that he reached.
 - * The pointer indicator gauge (reading the Civa+ and Civa- limits).
 - * His flying time in category "U" and in category "A".

Possible measuring errors or gauge mistakes will be detected by warning signals.

Programming :

A display screen with 2 lines of 16 digits and a keyboard (6 keys) allows reading and changing the counting, warning or sound signal Steps.

Different passwords give access to :

- the clock setting.
- the pointer indicator adjustment.
- Accelerometer configuration (in G+ and G-).
 - * CIVA limits.
 - * STEP 1 to 3.
 - * Choice of languages (4 languages for the display screen).
- Typical data storing (e.g. Pre-programming a CAP10).
- Setting the aircraft limit data.
- De-alariming.

All the above can be done through access codes. The accelerometer configuration code can be changed easily by the aircraft user (provided he does not loose it !).

Interesting Steps : (reading WITHOUT code).

<u>Positive data</u>	CAP 10 example	CAP 232
- aircraft limit	+ 6,1	+ 10,1
- overstress n°3	+ 5,8	+ 9,8
- overstress n°2	+ 5,6	+ 9,6
- overstress n°1	+ 5,4	+ 9,4
- civa limit	+ 5,1	+ 9,1
- audio signal starting	+ 3,5	+ 7,0
- category A limit	+ 3,3 (start of "aerobatics" time)	

<u>Negative data</u>	CAP 10 example	CAP 232
- category A limit	- 1,6 (start of "aerobatics" time)	
- audio signal starting	- 2,5	- 6,0
- civa limit	- 3,6	- 9,1
- overstress n°1	- 3,9	- 9,4
- overstress n°2	- 4,1	- 9,6
- overstress n°3	- 4,3	- 9,8
- aircraft limit	- 4,6	- 10,1

Information stored for each flight :

The 125 last flights are being stored (reading WITHOUT code).

- month from 0 to 12
- day from 01 to 31
- hours from 00 to 23
- minutes from 00 to 59
- flying time from 00 to 250 hundredths of hour
- aerobatics time from 00 to 250 hundredths of hour

- maxi G reached from 1,0 to +12,0 G)
- Step 3 overstress (Meter 4) from 00 to 250)
- Step 2 overstress (Meter 3) from 00 to 250) G+
- Step 1 overstress (Meter 2) from 00 to 250)
- civa overstress (Meter 1) from 00 to 250)

- maxi G reached from 1,0 to +12,0 G)
- Step 3 overstress (Meter 4) from 00 to 250)
- Step 2 overstress (Meter 3) from 00 to 250) G-
- Step 1 overstress (Meter 2) from 00 to 250)
- civa overstress (Meter 1) from 00 to 250)

Information stored independently from the flight : (reading WITHOUT code).

- maxi G+ and G- reached by the aircraft.
- number of overstress s in G+ and in G- of the aircraft limits.

PS : A flight which lasted over 2h50 hundredths would be closed while flying and immediately followed by a new stored information.

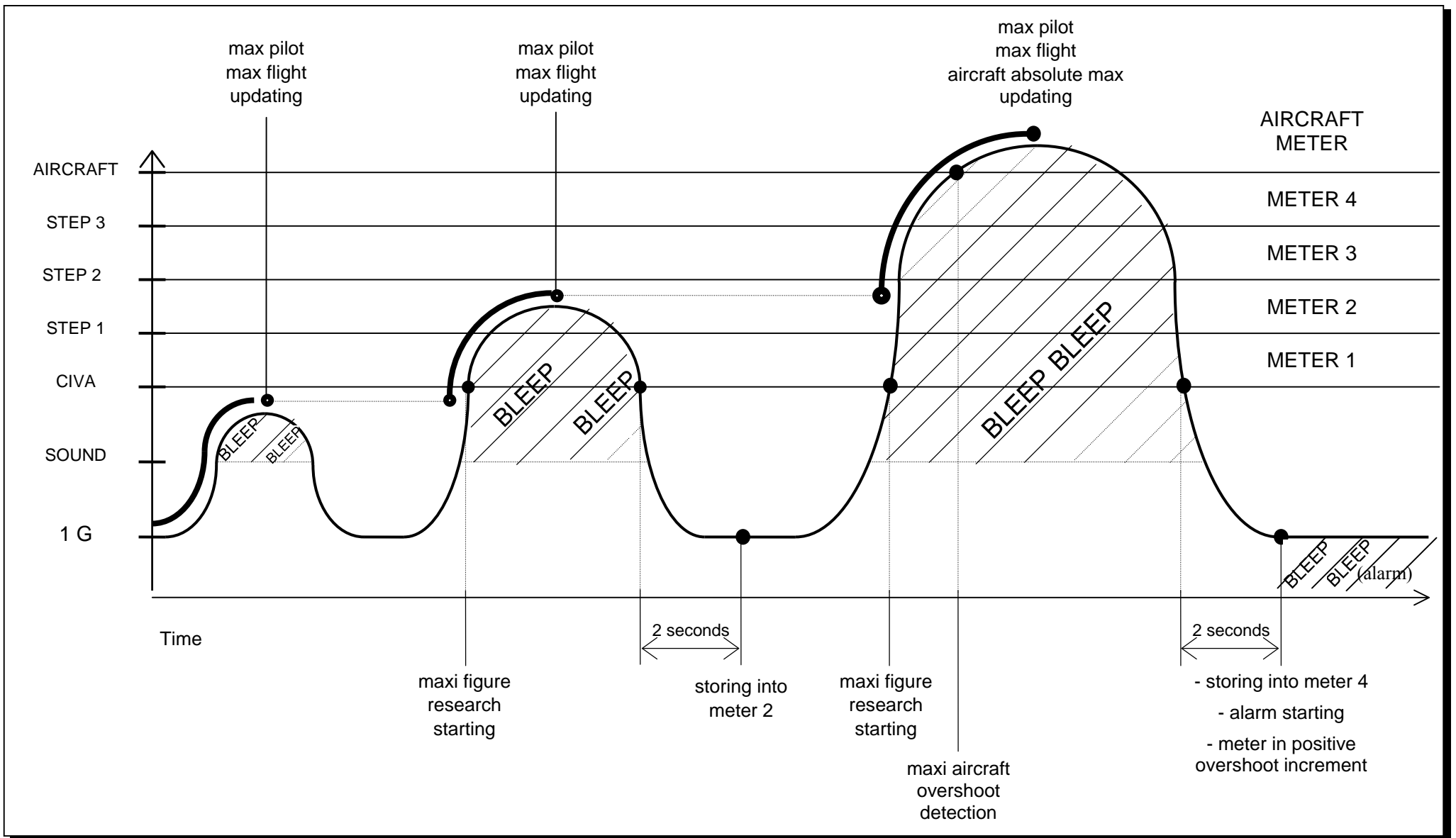

Keyboard actions :

KEYS	STAND BY	DURING FLIGHT
"ENTER"	to adjustment or reading	to adjustment or reading
"+"	-	G+ pilot storage reading
"-"	-	G- pilot storage reading
FLIGHT ("FLGT")	-	maximum reached since the start of the flight G+
FLIGHT ("FLGT") and "-"	-	maximum reached since the start of the flight G-
"CLUB"	-	G+ maximum authorised limit reading.
"CLUB" and "-"	-	G- maximum authorised limit reading.
"CLEAR"	-	Clearing pilot stored data

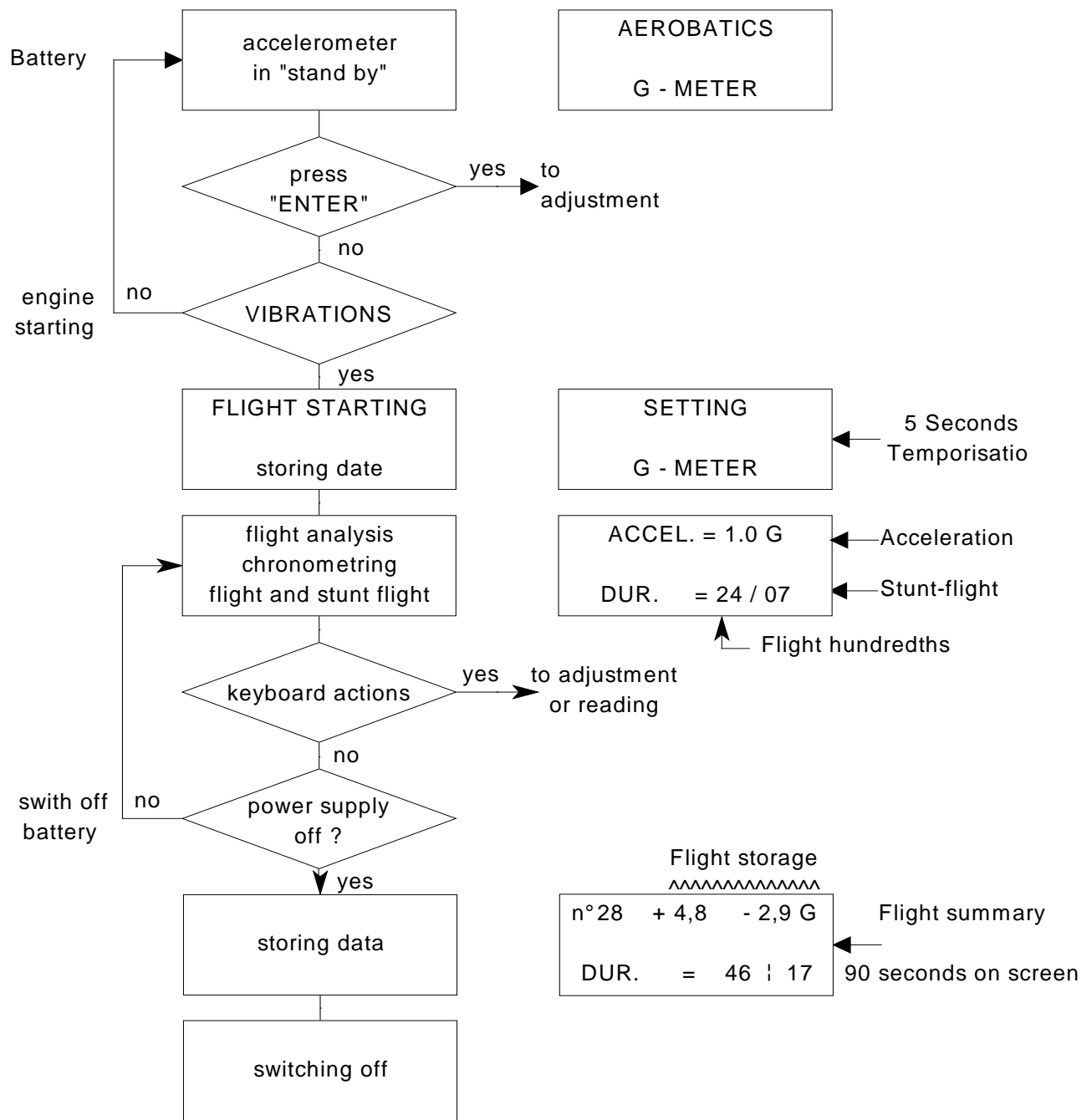

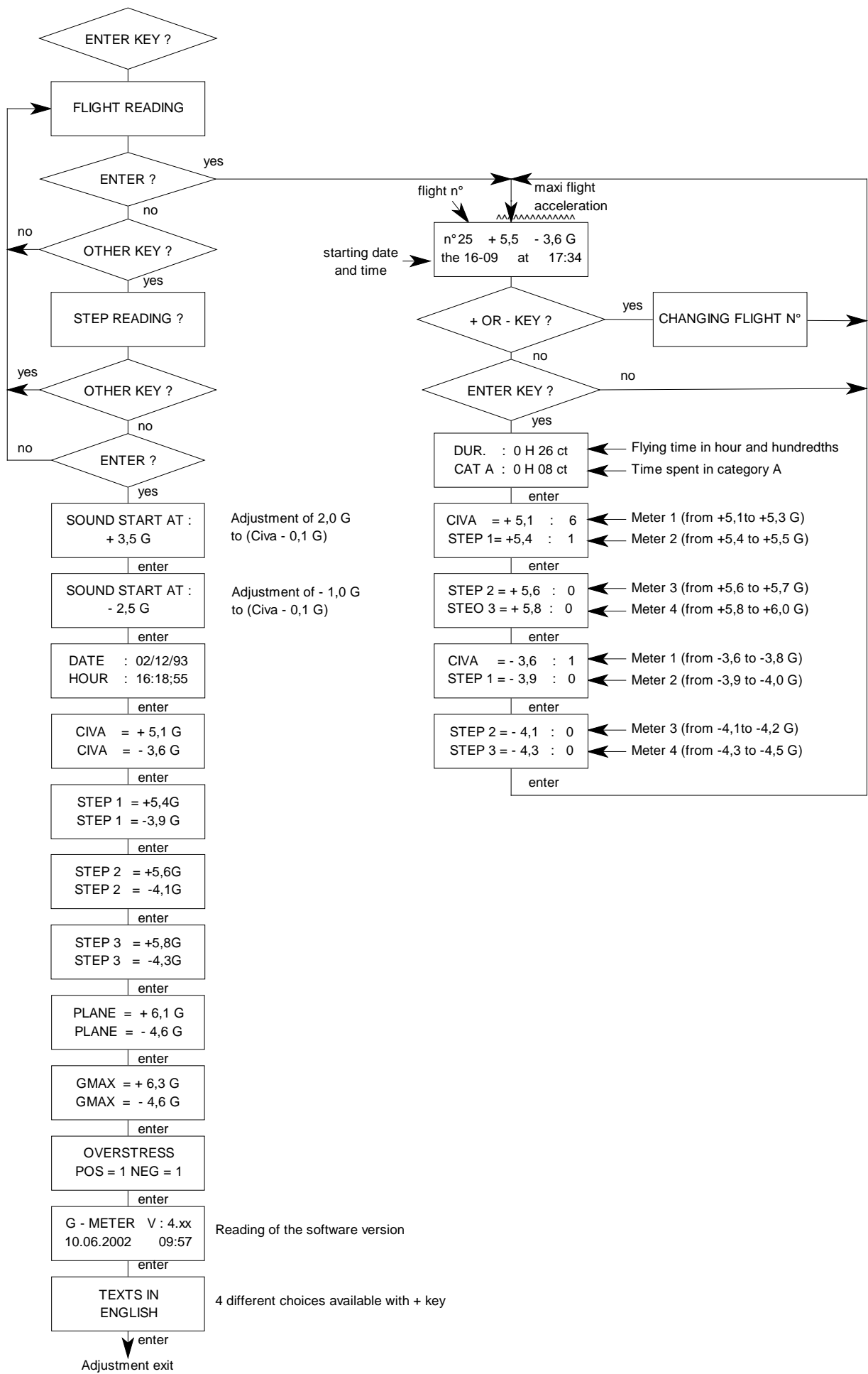

For the inquiring minds :

- The electronic sensor which is used is of capacitive type ; two membranes are being moved away or closer to each other by the acceleration and the variation of the electrical condenser they represent can then be measured. The sensor can detect accelerations from +/- 12G up to 200 times per second.

- The sensor measuring units are 12 bits (resolution 25 milli G) every 8 ms. An average of 8 measures on a 64-ms-period is reduced to 7 bits (plus the sign), every bit representing 0,1 G. Such data is then handled 16 times per second.

- The data handling is being done through a MOTOROLA microprocessor type 68HC12.

- The acceleration figure which appears on the display screen (and which a converter transforms in direct current) is available at the back plug to be indicated on a central-zero-ammeter.

A visual indication, similar to the mechanical accelerometers has then been established.

However, we draw your attention to the fact that this kind of indicator is somewhat slow taking between 0,2 to 0,3 seconds before showing the information on the display screen.

Mechanical assembling :

Adapting this accelerometer represents an important change to be approved by the local representative of aviation security, or by the aircraft's manufacturer.

The accelerometer is completely compatible in weight and volume to any traditional aeronautic instruments.

Setting the machine in a 80 mm drilling should therefore not be a problem.

The mechanical assembling is done with M4 screws which are provided.

It is recommended that the screws are secured with a special paste (at the back of the instrument).

Should you have any queries, do not hesitate to speak to the aircraft manufacturer, providing him with the following information :

- The weight : 650 grams.
- The length : 150 mm (connector excluded).
- The diameter : Ø 80 mm.
- The front socket : 83 x 83 mm square.

The place where to fix the instrument is not important, BUT

- The instrument is sensitive to the accelerations which occur on a vertical axis on the parallel of its setting plan (front face). The accelerations going from the "digital display screen" to the "keyboard" (reading direction of the texts on the front face) are considered as positive data. The accelerations going the other way round consider the G as negative.

Some versions of the instrument have been settled for a 20°-inclined-board (from the vertical axis).

The existence of an internal compensating wedge is marked with the 20 extension of the reference.

- Accelerometer for a vertical board :

Reference : PGM 1212 (before 10/95)
PGM 1212-00 (as from 10/95)

- Accelerometer for a 20°-inclined-board :

Reference : PGM1212-20

The most reliable information is provided in the center of the aircraft (application spot for the effects of the control surfaces).

The instrument shall indicate "-" and store "-" on each acceleration due to the vibrations of the surface on which it is held.

Should you have any difficulties (on a well-sprung panel board), strengthen the support shock absorption by any authorised means the aircraft manufacturer would accept (e.g. a foam rubber wedges or additional soundproof ...)

- The usual method of fixing is settled on a central position or straight to the panel board.

The ammeter shall preferably be set up in front of the pilot with the 4 supplied screws.

- weight : 270 grams
- depth behind board : 60 mm
- diameter : 80 mm
- front socket : cut angles 83 x 83 square

- Due to the necessary tests to be carried out after the cabling, it is recommended that the position where the instrument is settled should be carefully checked so that each part corresponds to its own connector, EVEN FOR THE PANEL BOARD ONCE IT IS SETTLED BACK.

Once you have checked all the above, you can undertake the cabling BEFORE OPERATING THE FIXING OF THE INSTRUMENT.

Instrument connection :

The instrument connection is operated through a lockable connector type Sub D, 9 pins.

The part which is fixed on the instrument is a male part.

The instrument should be switched on the 12 V (or 24 V on special versions) electric circuit on board, after the general switch. An on-line-diode and a 0,5 A automatic reset internal fuse protects the accelerometer.

Do never open the instrument.

The user must never interfere with the instrument.

Pin 5 : +12 V aircraft (80 mA maxi) (or 24 V - 80 mA).

Pin 8 : aircraft earth

The only suitable power supply for the accelerometer is 12 V. 24 V power supply require a special version of PGM 1212.

The suitable cable is :
- aeronautic flexible connecting cable
- gauge 24 to 20 (0,6 to 1 mm)
- an identification or coloured ring is advised to be used
such as : FILOTEX 1604 0,38.

The options are as follows :

- The repeating ammeter :

This instrument, central-zero sensitive +/- 500 μ A , is to be switched to the pins 9 (positive output) and 4 (negative output).

The maximum variation of the ammeter is adjusted by the accelerometer. The compulsory access PINS for such adjustment are to be found in a sealed envelope held by the civa manager.

- The audio signal :

The accelerometer gives an audio signal of 100 mW (maxi ; set up with a screw driver in the volume mark) in a completely isolated way thanks to an AF transformer.

It is possible to operate this audio signal in two different ways :

- 1) a) connect pin 1 or 6 to the earth of the radio,
b) connect the other pin to the auxiliary exit of the radio.
In such case the 22 Ω 3 W resistance is of no use.

- 2) a) open the AF output circuit on line
b) connect pins 1 to 6 on line (no matter the order)

c) connect the provided 22 Ω 3 W resistance within or nearby the connector in parallel to pins 1 to 6. This resistance ensures a continuous audio signal should the accelerometer exit converter fail or in the case of disassembling of the instrument.

Be careful not to ever short circuit directly pins 1 and 6 together.

Connector Sub D

- Pin
- 1 audio signal
 - 2 reserved (oil pressure)
 - 3 reserved (engine speed meter)
 - 4 repeating ammeter "-"
 - 5 supply +12 V or 24 V.
 - 6 audio signal
 - 7 reserved
 - 8 earth (negative supply)
 - 9 repeating ammeter "+"

+++++

On line cabling

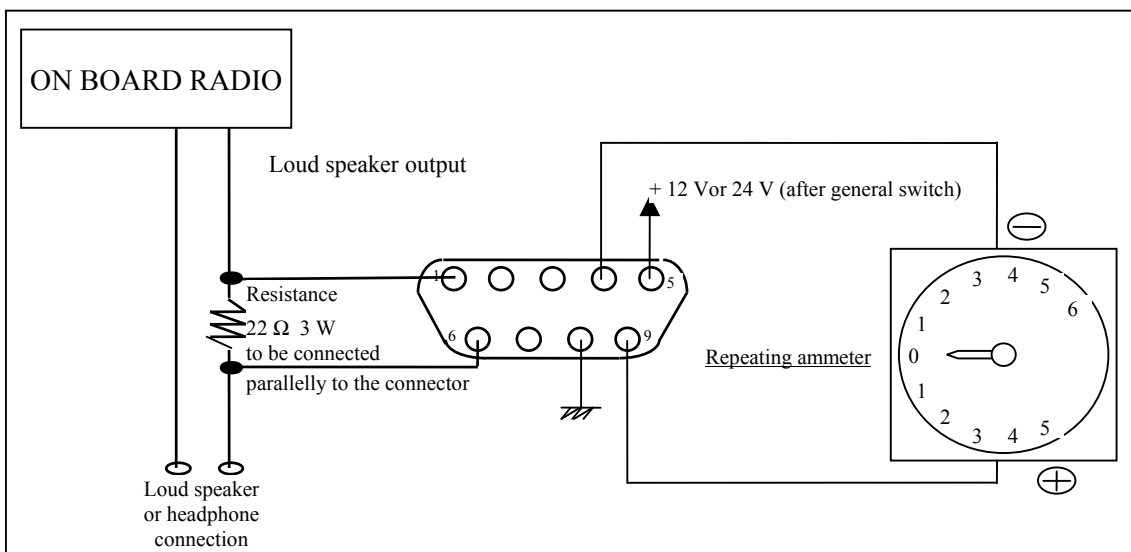

Cabling on auxiliary input

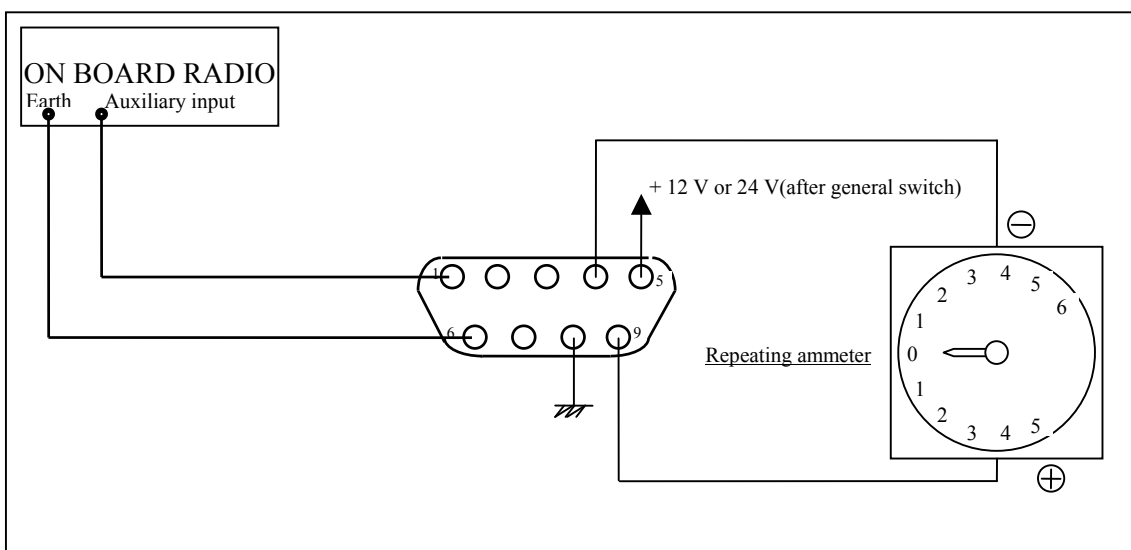

First Switching on :

- Place the accelerometer horizontally. For the special version provided for sloping panels of 20°, the calibration test must be done on an inclined board as following :

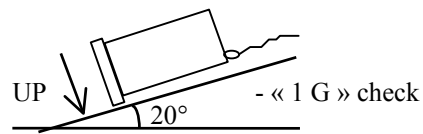
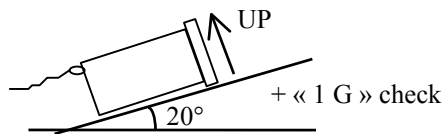

- Switch it on
The accelerometer should show
and the red signal light should be on. (LED)

AEROBATICS G-METER

- The pointer indicator should show +1 G. If not, apply the adjustment procedure. See the special notification on adjustment given to the Civa manager.

- Tap the accelerometer :
It should then indicate :

ACCEL. : +1,0 G
DUR. : 00100

- Turn the accelerometer 90° on the left (or right) and put it back, its edge on the same horizontal surface.
The instrument should indicate :

ACCEL. : (-) 0,0 G
DUR. : 00100

(The "-" sign can or cannot be indicated).

- Place the accelerometer on its back.
It should show - 1,0 G.

Once the gauge check has been carried out, the instrument can then be fixed to the panel board.

It is recommended that all the screw should be secured with special paste.

- Once set up, use the "contrast" adjustment to facilitate the reading of the liquid cristal display.

- The last step is the configuration of the accelerometer, done by the person in charge of the machine who shall also ensure the gauge of the ammeter if necessary.

Periodical checks :

Gauging :

Serious gauging mistakes are detected by the instrument and appear on the display screen as "gauging mistake".

However, small failures can be tested using the "switching on" procedure of the handbook PGM 1212 V 4.

For any mistake over 0,3 G, the instrument will be left over and a gauging procedure has to be carried out.

Every year such test will be carried out during the annual check.

Internal battery :

After the aircraft has been switched off, the accelerometer will continue to measure on an internal accumulators battery (9 V ; 100 to 120 mAh). It stops when the aircraft has come to a complete halt. (See enclosed chart).

Ensure that the instrument to record after switching off the power supply. Simulate the movement of "vibrations" by gently shaking the instrument (mind the shocks which quickly represent important G !).

- A normally full battery (after 3 hour flying time) should last about 2 h 30 mns. Check it for just a few minutes.

- A low battery which will not last after the end of the flight was detected, (no more movements or vibrations) will produce recording mistakes (odd data). Such failure can be detected by the message "error of TIMER" on the next switch on.

- In order to avoid any errors, the standard battery should be changed every 5 years. (VARTA Ni.MH 9 V 120 mAh type 5522 or equivalent).

Clock battery :

The battery of the internal clock is a "AA" lithium type (SAFT LS 14500, 3,6 V or equivalent).

This battery which was designed to last for 5 to 10 years should be replaced every 5 years. After replacing, operate the clock setting using the confidential access codes.

Enclosures :

Sampling of the provided pieces :

- Major change approval dated 31/08/95 for the CAP 10 accelerometer.
- Example for updating the flight handbook.